

## HD93 SERVICE MANUAL MODELS

11487TK-US    HD93 – 870 Teak  
11488TK-US    HD93 – 880 Teak



Ebac Industrial Products, Inc.  
700 Thimble Shoals Blvd, Suite 109  
Newport News, VA. 23606-2575  
Tel: (757) 873 6800 Fax: (757) 873 3632  
Website [www.ebacusa.com](http://www.ebacusa.com)

## INDEX

<b>DESCRIPTION</b>	<b>PAGE No.</b>
1.0 SAFETY NOTES & GENERAL ADVICE	3
2.0 DISMANTLING NOTES	3
3.0 PART NUMBERS	4
4.0 SERIAL NUMBERS	5
5.0 SPECIFICATIONS	6
6.0 GENERAL INFORMATION	7
6.1 Basic Principles	
6.2 Refrigeration System	
6.3 Defrost	
6.4 Water Extraction Rules	
7.0 COMPONENT FUNCTION	9
7.1 Humidistat	
7.2 Controller	
8.0 COMPRESSOR	10
8.1 Starting	
8.2 Electrical Connections	
9.0 WIRING INFORMATION	12
9.1 Controller Identification pre 57009802	
9.2 Controller Identification post 57009802	
9.3 Wiring information	
10.0 COMPONENT IDENTIFICATION	18
11.0 SPARE PARTS LISTING	21
12.0 FAULT DIAGNOSIS	26

## 1.0 SAFETY NOTES AND GENERAL ADVICE

1. This manual is NOT intended as a comprehensive repair/maintenance guide to the appliance
2. It is ONLY for use by qualified persons having technical competence, applicable product knowledge and suitable service test tools/equipment.
3. Servicing of electrical equipment must be undertaken with the appliance disconnected (unplugged) from the electrical supply.
4. Servicing must be preceded by, and followed by, an earth continuity and insulation check.
5. Personal safety precautions must be taken to protect against accidents caused by sharp edges on metal and plastic parts.
6. After servicing, the equipment must be re-checked for electrical safety.
7. It may be dangerous to attempt "DIY" repairs/maintenance, Ebac recommends that in the event of any technical service problems advice be sought from their service department.
8. Ebac customer services may be contacted on (757) 873 6800 during normal office hours.

## 2.0 INSTRUCTIONS FOR THE REMOVAL OF THE UNIT FROM THE CABINET

### **STEP 1 - Remove The Mains Cable And Connector**

Open the mains cable connector using a screwdriver to lever open the catches either side. Remove the two central fixing screws located inside and pull the connector clear of the back panel.  
Disconnect the three wires at the back of the connector, making note of their connected positions.

### **STEP 2 - Remove The Unit Fixing Screws**

Remove the two screws either side of the controls housing at the top front.  
Remove the two screws from the back panel.

### **STEP 3 - Slide The Unit Out Of The Cabinet**

### 3.0 PART NUMBERS

From the part number you can determine the Model number using 1<sup>st</sup> & 2<sup>nd</sup> digit and adding a zero i.e. 11466TK-GB is a Homedry 660 teak for the UK market

HOMEDRY 114 X X X X - X X  
1<sup>ST</sup> 2<sup>ND</sup> COLOUR COUNTRY

1st Digit = Refrigeration capacity. A higher number means a higher capacity.

4 = 3.9cc Compressor, 337 Watts Cooling

6 = 5.6cc Compressor, 510 Watts Cooling

8 = 5.9cc Compressor, 590 Watts Cooling

9 = 8.85cc Compressor 700 Watts Cooling

2nd Digit = Controls/functions series (see controller identification)

4 = Humidistat, bucket full LED, power on LED

6 = Humidistat, 2 speed fan, bucket full LED, bucket 3/4 full LED, power LED.

7 = Humidistat, 3 Speed fan & off position, bucket full LED, bucket 3/4 full LED, power on LED.

8 = Humidistat, 3 Speed fan & off position, bucket full LED, bucket 3/4 full LED, power on LED, continuous fan switch.

#### 4.0 SERIAL NUMBER

The current system of date code and serial number is a continuous 8 digit number, the first two digits form the date code and indicate the month and year of manufacture (see table below) the next six digits give the unit number of the individual machine.

**SERIAL NUMBER** - Is located on a sticker behind the water container.

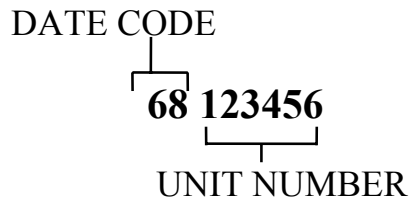

#### DATE CODE

	1994	1995	1996	1997	1998	1999	2000	2001
<b>Jan</b>	01	13	25	37	49	61	73	85
<b>Feb</b>	02	14	26	38	50	62	74	86
<b>Mar</b>	03	15	27	39	51	63	75	87
<b>Apr</b>	04	16	28	40	52	64	76	88
<b>May</b>	05	17	29	41	53	65	77	89
<b>Jun</b>	06	18	30	42	54	66	78	90
<b>July</b>	07	19	31	43	55	67	79	91
<b>Aug</b>	08	20	32	44	56	68	80	92
<b>Sep</b>	09	21	33	45	57	69	81	93
<b>Oct</b>	10	22	34	46	58	70	82	94
<b>Nov</b>	11	23	35	47	59	71	83	95
<b>Dec</b>	12	24	36	48	60	72	84	96

(This is a 96 digit number sequence which repeats every 8 years)

## 5.0 SPECIFICATIONS

	UNIT TYPE	
	HOMEDRY 11487TK-US	HOMEDRY 11488TK-US
Unit Height mm	576	
Unit Width mm	344	
Unit Depth mm	287	
Weight (EMPTY) kg	18.5	18.5
Operating Range	13°C/55F to 35°C/95F	
Max Water Extraction Rate (32≡c @ 90% RH)	12 Litres/day	12 Litres/day
Typical water Extraction Rate (18≡c @ 55% RH)	125ml/hr	125ml/hr
Power consumption (18≡c @55% RH)	305 watts	305 watts
Refrigerant Charge R134a	185g	185g
Compressor (Figures quoted are for Tecumseh / Embraco)	AZ0413YS 5.9cc 590 watts	AZ0413YS 5.9cc 590 watts
Capillary	0.036" x 1000mm	0.036" x 1000mm
Fuse Rating	5 amps (After Year 2000)	
Filter Dryer	XH7	XH7

## 6.0 GENERAL INFORMATION

### 6.1 BASIC PRINCIPLES

The purpose of a dehumidifier is to extract water from the air, in order that dampness or condensation in the house is reduced. Unlike an air conditioner a dehumidifier does not cool the air. The air being passed through the system is warmed before being recirculated which results in a slight rise in temperature. A dehumidifier is basically a refrigeration system with a fan to provide air circulation. The fan draws air over the evaporator coil which provides a large cold surface area on which the moisture in the air condenses. The system condenser is positioned between the evaporator and the fan in order to warm the cold dry air before blowing it back into the room. The water that condenses runs into a drain tray and is collected in a water container.

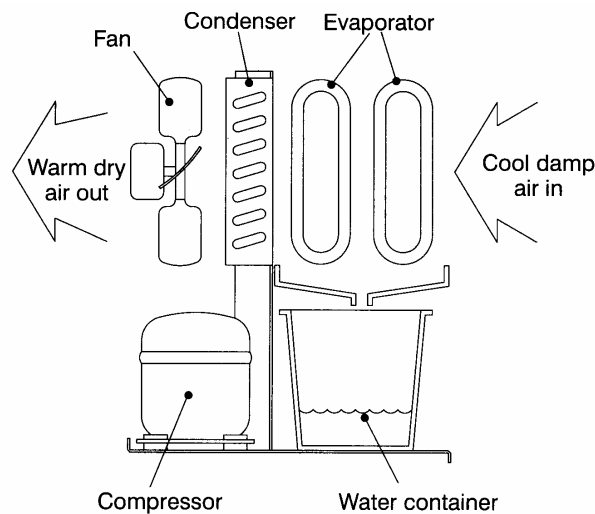

### 6.2 REFRIGERATION SYSTEM

The evaporator (tubes visible through the air filter) are cooled by a refrigeration system which utilises a compressor to pump refrigerant around a hermetically sealed circuit. The exact amount of refrigerant is carefully metered into the unit during manufacture. This is vital for effective operation. When the unit is correctly charged the evaporator temperature will typically be at 0°C when the air temperature is between 24°C and 28°C. The evaporator temperature varies with air temperature and humidity. The higher the air temperature and humidity the higher the evaporating temperature. When correctly charged the evaporator will be wet/frosted between 3/4 and all the way along its visible section.

**Note: The dehumidifier does not reach working temperature until approximately 30 minutes after switch on.**

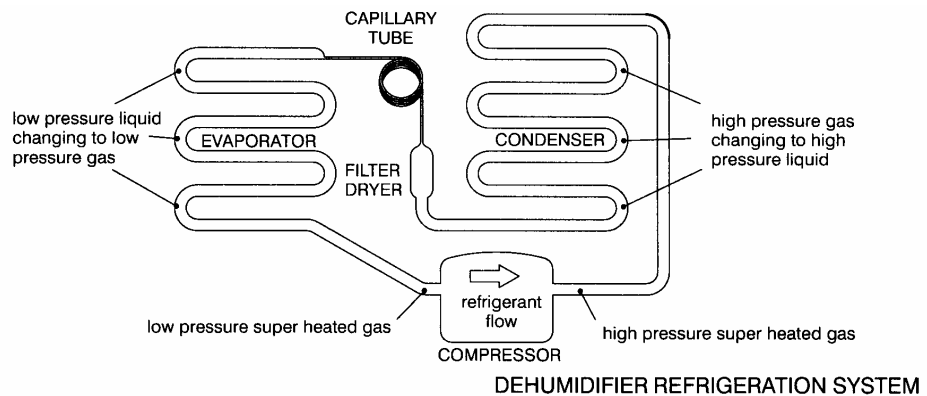

### 6.3 DEFROSTING

At low air temperatures the evaporator operates below 0°C and hence the moisture extracted from the air freezes on the evaporator coils. This frost is periodically removed by an automatic defrost system known as IDS:-

- Defrost mode is, compressor off, fan on, The warm air melts the frost.
- The defrost duration and time between defrost cycles vary according to air temperature. Above 35°C ± 1°C no defrost occurs.

### 6.4 WATER EXTRACTION GENERAL RULES

The amount of water extracted will depend on the amount of water in the air. As a general rule, the colder the outside temperature, the less water will be in the air.

Do not position the dehumidifier near a radiator or outside door as this will reduce the effectiveness. Water extraction varies with the following parameters:-

- Air temperature
- Air humidity
- Unit positioning
- Unit fan speed setting (higher fan speed, higher extraction)
- Loss of refrigeration charge (gives low extraction, note less than half the evaporator will be wet or frosted).

See technical specification for typical water extraction information.

## 7.0 COMPONENT FUNCTION

7.1 Humidistat -Will switch the unit on/off in response to changing humidity. The humidistat is effectively a nylon membrane and micro switch. The nylon membrane shortens as it dries, and the shortening effect switches a micro-switch, which turns the fan and the compressor off. If the humidistat is ever examined it is vital that all the sealing around the controls compartment is replaced else the humidistat will not see room air.

7.2 Control Module - Is located on top of the fan housing (clam shell). The latest module is microprocessor controlled and performs 4 basic functions:-

### **a). Fan speed/continuous**

Fan speeds are determined by switching power resistors into the fan supply circuit in high speed, two power resistors re working in parallel.

### **b). Timed Defrost**

See general operation earlier.

The temperature sensor that determines the defrost/run cycle is located on the same PCB as the power and bucket LED'S.

**If the sensor is ever examined it is vital that all sealing around the controls compartment is replaced, else the sensor will not see the correct ambient temperature.**

### **c). Bucket Level Switches**

A float and lever system at the rear of the water container activates 2 NC micro-switches (1 in 400 models). the LHS micro-switch is the bucket full switch. The RHS switch being the bucket 3/4 full.

If the water container is not in position, the switches are NC and the unit cannot be started.

When the empty container is in position and the door closed, both switches are open and the unit can be started.

When the container is 3/4 full, the RHS micro-switch closes and the red LED flashes. When the container is full the LHS micro-switch closes, the red LED is full on and the unit stops running.

### **d). Compressor 4 Minute Delay**

When a refrigeration compressor is switched off manufacturers advise against switching straight back on in order to allow the refrigerant pressures to equalise.

**If the dehumidifier is switched off by any means, except at the mains, the compressor will automatically stay off for 4 minutes.**

## 8.0 COMPRESSOR

### 8.1 Starting

The compressor is hermetically sealed and is not serviceable except for the electrical components located inside the plastic cover.

When the compressor starts up it starts on two sets of windings called, start windings and run windings. After a fraction of a second the start relay drops the start windings out of the circuit and the compressor runs on run windings only.

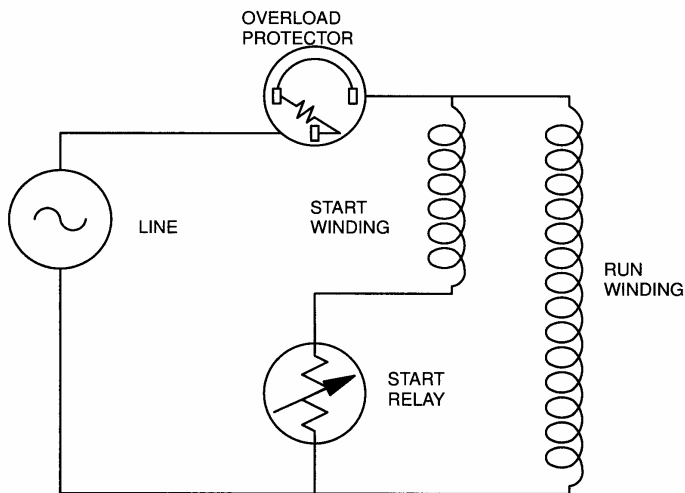

If the start windings are not dropped out then the overload protector will trip the power after 5 to 10 seconds. The overload protector resets itself after a few minutes.

## 8.2 Electrical Connections

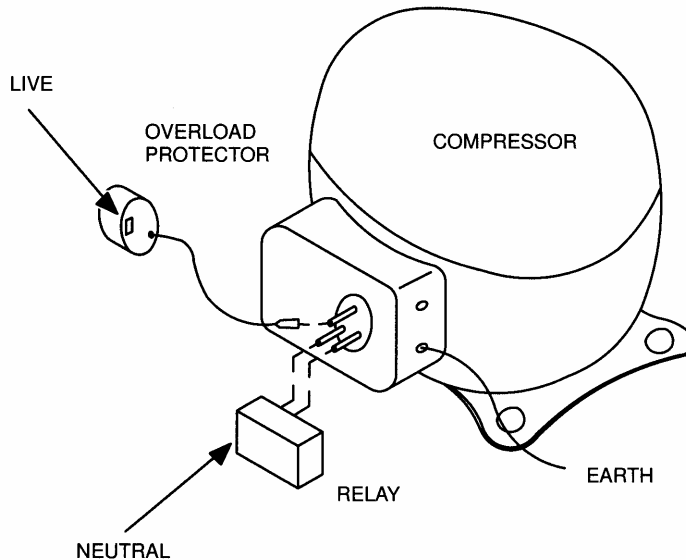

### Brazing

The 1/4" suction and process connections on the compressor are copper. The recommended braze rods on these connections are Phos 2.

The 3/16" discharge connection is steel. The recommended braze rods on these connections are 30% silver solder.

**On 900 Series all connections on the compressor are copper.**

### Re-Charge

When re-charging the compressor the system should be vacuum dehydrated down to a pressure of 1 mbar. Also the capillary tube and filter drier must be changed. The charge should be accurately metered into the quantity specified on the rating label. The rating label is located behind the water container.

9.0 **WIRING INFORMATION**  
9.1 **CONTROLLER IDENTIFICATION PRE SERIAL No: 57009802**

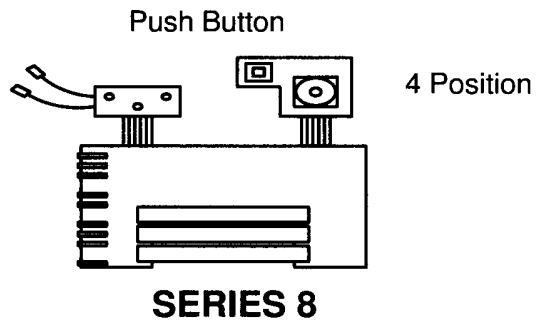
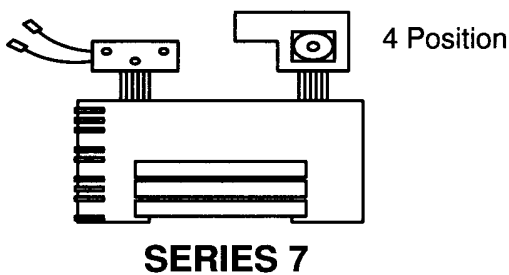
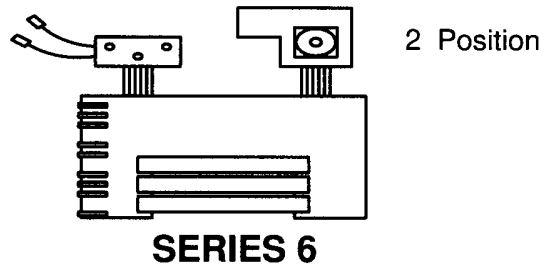
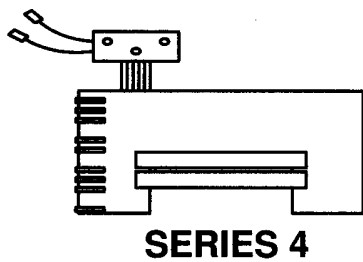

**CONNECTION CHART**

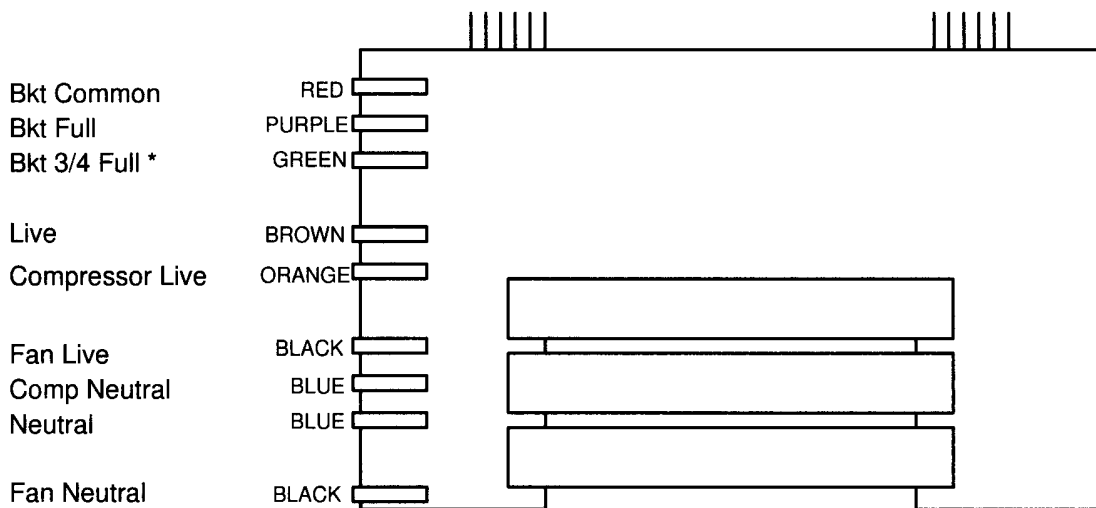

\* Not connected on series 4 controller

### 9.2 PCB IDENTIFICATION FROM SERIAL No: 57009802

This core PCB is now a standard fitting to all HD93 models after serial number 57009802. It is accompanied by a different array of switches depending on the model. Defrost cycles are also common to all models.

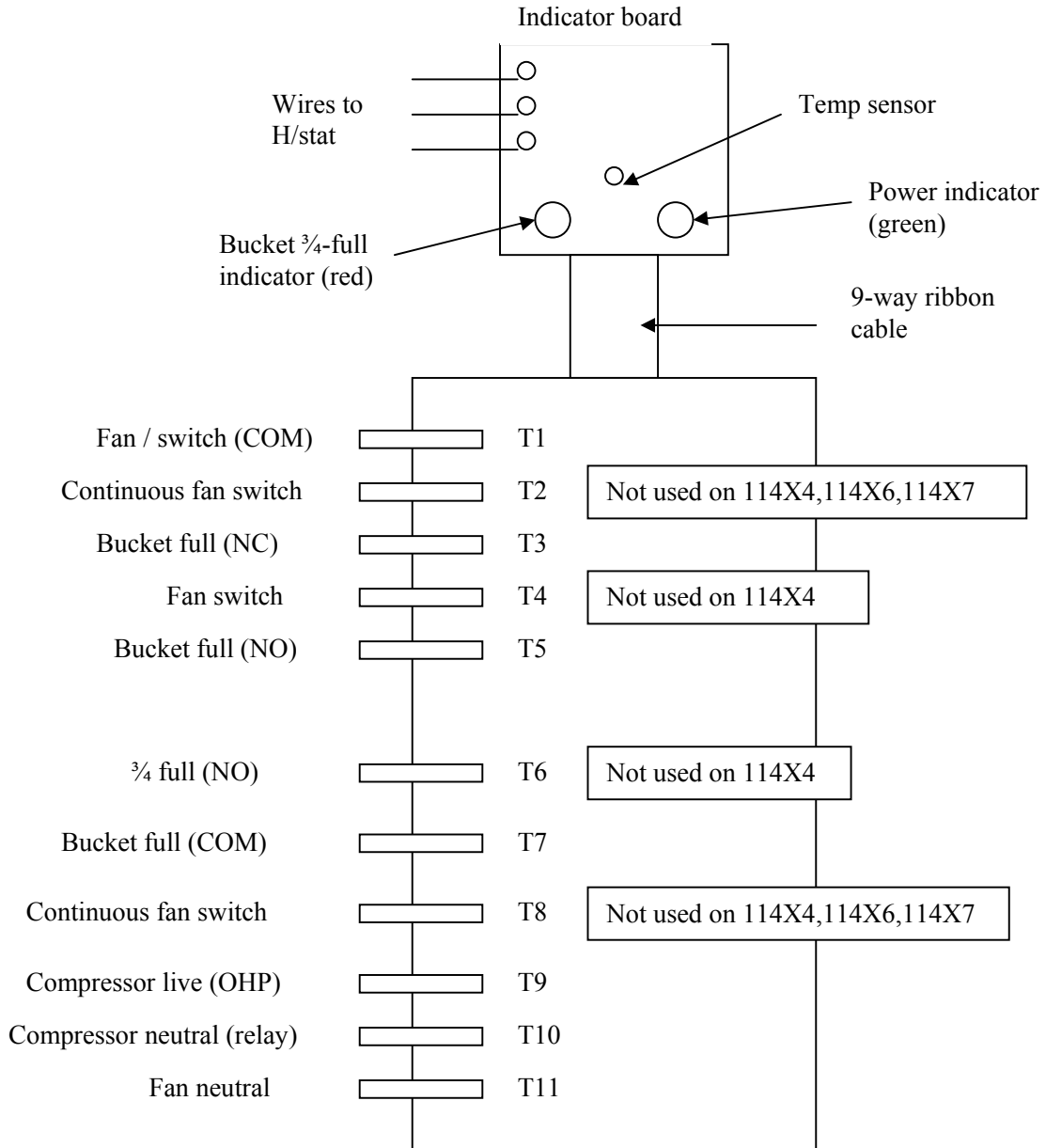

### 9.3 WIRING INFORMATION

Wiring information(after serial 57009802) for models:- 11444 (440), 11464 (640)

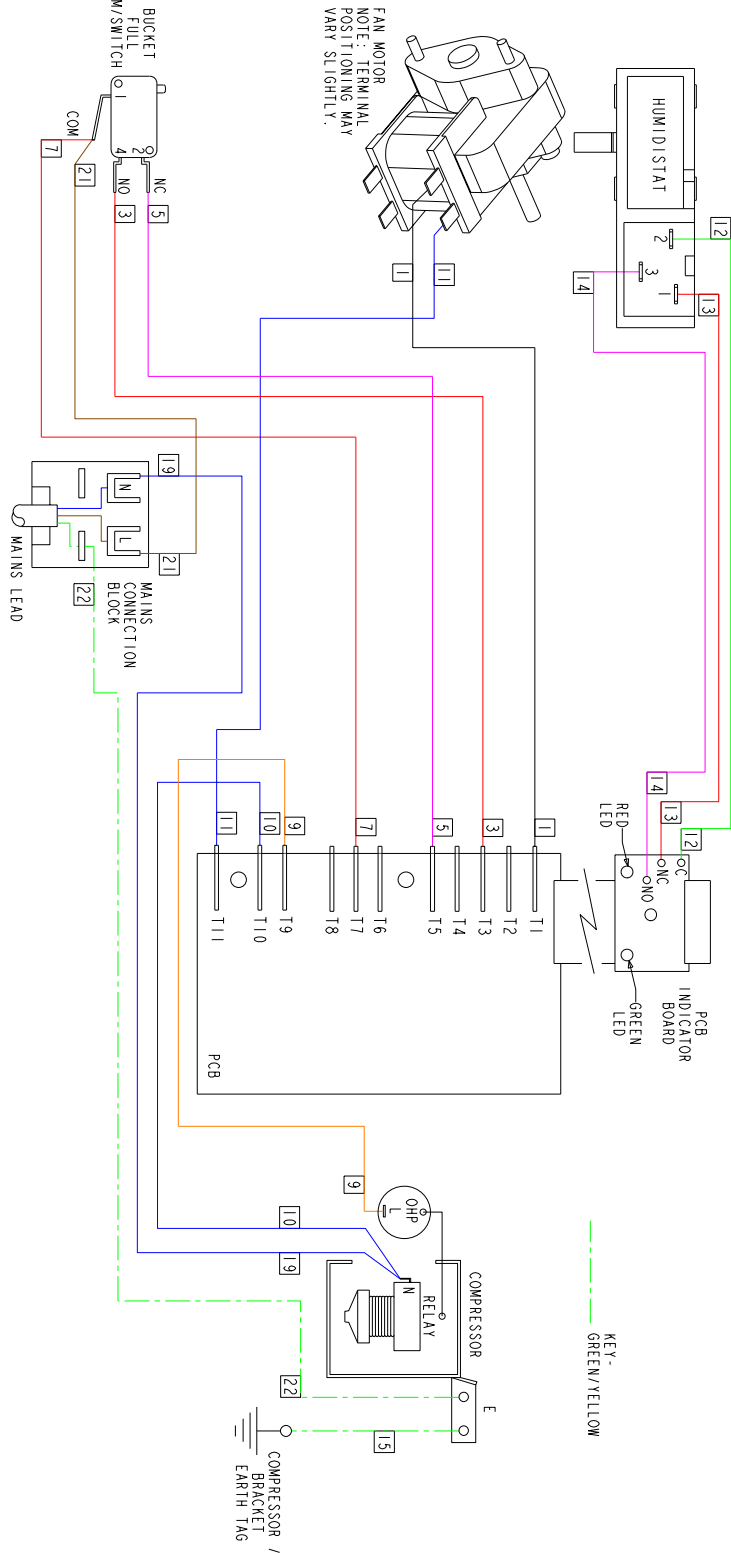

WIRE No.	FROM	TERMINATION	TO	TERMINATION	COLOUR	PART No.
1	PCB T1	2.8mm FASTON & BOOT	FAN MOTOR (SEE DIAGRAM)	6.3mm FASTON & BOOT	BLACK	3036866
2	PCB T2	---	---	---	---	---
3	PCB T3	2.8mm FASTON & BOOT	BUCKET FULL M/SWITCH (4)	6.3mm FASTON & BOOT	RED	3036851
4	PCB T4	---	---	---	---	---
5	PCB T5	2.8mm FASTON & BOOT	BUCKET FULL M/SWITCH (2)	6.3mm FASTON & BOOT	VIOLET	3036852
6	PCB T6	---	---	---	---	---
7	PCB T7	2.8mm FASTON & BOOT	BUCKET FULL M/SWITCH (1)	6.3mm PIGGYBACK FASTON	RED	3036850
8	PCB T8	---	---	---	---	---
9	PCB T9	2.8mm FASTON & BOOT	COMPRESSOR OHP (L)	6.3mm FASTON	ORANGE	3036848
10	PCB T10	2.8mm FASTON & BOOT	COMPRESSOR RELAY (N)	6.3mm FASTON	BLUE	3036849
11	PCB T11	2.8mm FASTON & BOOT	FAN MOTOR (SEE DIAGRAM)	6.3mm FASTON & BOOT	BLUE	3036851
12	PCB INDICATOR BOARD (C)	SOLDER	HUMIDISTAT (2)	6.3mm 90° FLAG & BOOT	GREEN	3036855
13	PCB INDICATOR BOARD (NC)	SOLDER	HUMIDISTAT (1)	6.3mm 90° FLAG & BOOT	RED	3036856
14	PCB INDICATOR BOARD (NO)	SOLDER	HUMIDISTAT (3)	6.3mm 90° FLAG & BOOT	VIOLET	3036865
15	COMPRESSOR (E)	M4 FORK	COMPRESSOR / BRACKET EARTH TAG	M4 RING	GRN/YELL	3036847
16	---	---	---	---	---	---
17	---	---	---	---	---	---
18	---	---	---	---	---	---
19	MAINS CONNECTION BLOCK (N)	6.3mm FASTON & BOOT	COMPRESSOR RELAY (N)	6.3mm PIGGYBACK FASTON	BLUE	3036843
20	---	---	---	---	---	---
21	MAINS CONNECTION BLOCK (L)	6.3mm FASTON & BOOT	BUCKET FULL M/SWITCH (1)	6.3mm FASTON & BOOT	BROWN	3036845
22	MAINS CONNECTION BLOCK (E)	6.3mm LOCKING FASTON	COMPRESSOR (E)	M4 FORK	GRN/YELL	3036846

Wiring information (after serial 57009802) for models:- 11446 (460), 11466 (660)

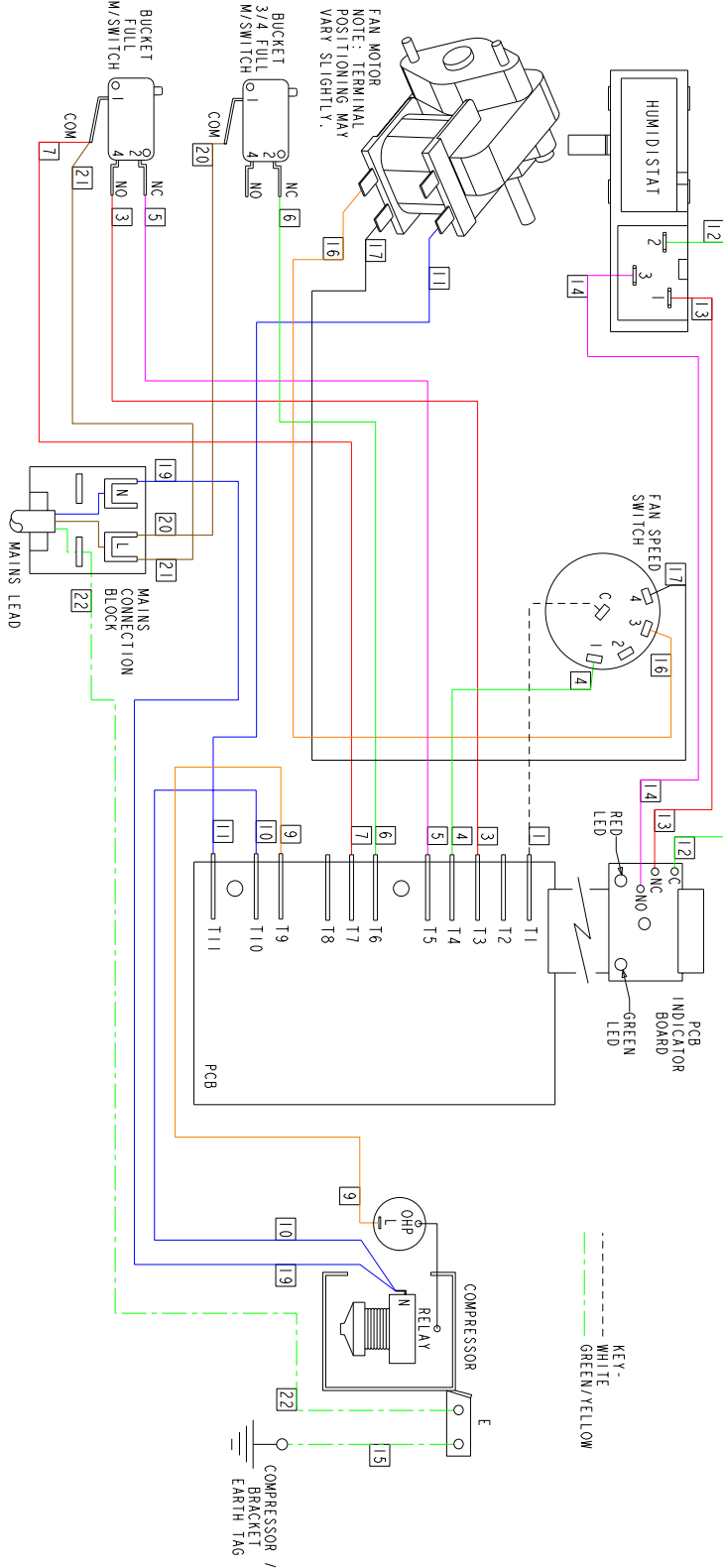

WIRE No.	FROM	TERMINATION	TO	TERMINATION	COLOR	PART No.
1	PCB T1	2.8mm FASTON & BOOT	FAN SPEED SWITCH (C)	SOLDER	WHITE	3036862
2	PCB T2	---	---	---	---	---
3	PCB T3	2.8mm FASTON & BOOT	BUCKET FULL M/SWITCH (4)	6.3mm FASTON & BOOT	RED	3036851
4	PCB T4	2.8mm FASTON & BOOT	FAN SPEED SWITCH (1)	SOLDER	GREEN	3036861
5	PCB T5	2.8mm FASTON & BOOT	BUCKET FULL M/SWITCH (2)	6.3mm FASTON & BOOT	VIOLET	3036852
6	PCB T6	2.8mm FASTON & BOOT	BUCKET 3/4 FULL M/SWITCH (2)	6.3mm FASTON & BOOT	GREEN	3036853
7	PCB T7	2.8mm FASTON & BOOT	BUCKET FULL M/SWITCH (1)	6.3mm PIGGYBACK FASTON	RED	3036850
8	PCB T8	---	---	---	---	---
9	PCB T9	2.8mm FASTON & BOOT	COMPRESSOR OHP (L)	6.3mm FASTON	ORANGE	3036848
10	PCB T10	2.8mm FASTON & BOOT	COMPRESSOR RELAY (N)	6.3mm FASTON	BLUE	3036849
11	PCB T11	2.8mm FASTON & BOOT	FAN MOTOR (SEE DIAGRAM)	6.3mm FASTON & BOOT	BLUE	3036857
12	PCB INDICATOR BOARD (C)	SOLDER	HUMIDISTAT (2)	6.3mm 90° FLAG & BOOT	GREEN	3036855
13	PCB INDICATOR BOARD (NC)	SOLDER	HUMIDISTAT (1)	6.3mm 90° FLAG & BOOT	RED	3036856
14	PCB INDICATOR BOARD (NO)	SOLDER	HUMIDISTAT (3)	6.3mm 90° FLAG & BOOT	VIOLET	3036854
15	COMPRESSOR (E)	M4 FORK	COMPRESSOR / BRACKET EARTH TAG	M4 RING	GRN/YELL	3036847
16	FAN SPEED SWITCH (3)	SOLDER	FAN MOTOR (SEE DIAGRAM)	6.3mm FASTON & BOOT	ORANGE	3036858
17	FAN SPEED SWITCH (4)	SOLDER	FAN MOTOR (SEE DIAGRAM)	6.3mm FASTON & BOOT	BLACK	3036859
18	---	---	---	---	---	---
19	MAINS CONNECTION BLOCK (N)	6.3mm FASTON & BOOT	COMPRESSOR RELAY (N)	6.3mm PIGGYBACK FASTON	BLUE	3036843
20	MAINS CONNECTION BLOCK (L)	6.3mm FASTON & BOOT	BUCKET 3/4 FULL M/SWITCH (1)	6.3mm FASTON	BROWN	3036844
21	MAINS CONNECTION BLOCK (1)	6.3mm FASTON & BOOT	BUCKET FULL M/SWITCH (1)	6.3mm FASTON & BOOT	BROWN	3036845
22	MAINS CONNECTION BLOCK (E)	6.3mm LOCKING FASTON	COMPRESSOR (E)	M4 FORK	GRN/YELL	3036846

Wiring information (after serial 57009802) for models:- 11447 (470), 11467 (670), 11487 (870), 11497 (970)

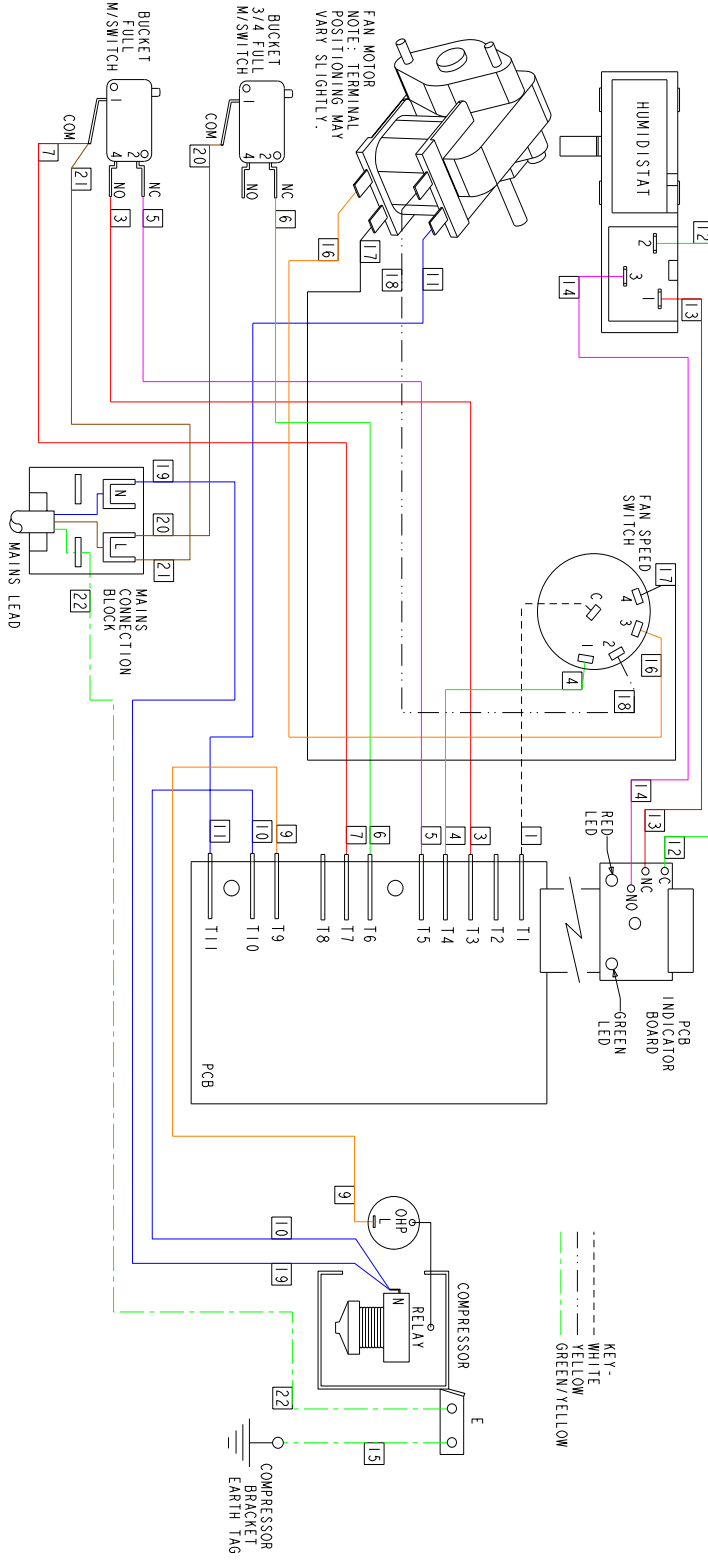

WIRE No.	FROM	TERMINATION	TO	TERMINATION	COLOR	PART No.
1	PCB T1	2.8mm FASTON & BOOT	FAN SPEED SWITCH (C)	SOLDER	WHITE	3036862
2	PCB T2	---	---	---	---	---
3	PCB T3	2.8mm FASTON & BOOT	BUCKET FULL M/SWITCH (4)	6.3mm FASTON & BOOT	RED	3036851
4	PCB T4	2.8mm FASTON & BOOT	FAN SPEED SWITCH (1)	SOLDER	GREEN	3036861
5	PCB T5	2.8mm FASTON & BOOT	BUCKET FULL M/SWITCH (2)	6.3mm FASTON & BOOT	VIOLET	3036852
6	PCB T6	2.8mm FASTON & BOOT	BUCKET 3/4 FULL M/SWITCH (2)	6.3mm FASTON & BOOT	GREEN	3036853
7	PCB T7	2.8mm FASTON & BOOT	BUCKET FULL M/SWITCH (1)	6.3mm PIGGYBACK FASTON	RED	3036850
8	PCB T8	---	---	---	---	---
9	PCB T9	2.8mm FASTON & BOOT	COMPRESSION OHP (L)	6.3mm FASTON	ORANGE	3036848
10	PCB T10	2.8mm FASTON & BOOT	COMPRESSION RELAY (N)	6.3mm FASTON	BLUE	3036849
11	PCB T11	2.8mm FASTON & BOOT	FAN MOTOR (SEE DIAGRAM)	6.3mm FASTON & BOOT	BLUE	3036857
12	PCB INDICATOR BOARD (C)	SOLDER	HUMIDISTAT (2)	6.3mm 90° FLAG & BOOT	GREEN	3036855
13	PCB INDICATOR BOARD (NC)	SOLDER	HUMIDISTAT (1)	6.3mm 90° FLAG & BOOT	RED	3036856
14	PCB INDICATOR BOARD (NO)	SOLDER	HUMIDISTAT (3)	6.3mm 90° FLAG & BOOT	VIOLET	3036854
15	COMPRESSOR (E)	M4 FORK	COMPRESSION RELAY / BRACKET EARTH TAG	M4 RING	GRN/YELL	3036847
16	FAN SPEED SWITCH (3)	SOLDER	COMPRESSION RELAY (N)	6.3mm FASTON & BOOT	ORANGE	3036858
17	FAN SPEED SWITCH (4)	SOLDER	FAN MOTOR (SEE DIAGRAM)	6.3mm FASTON & BOOT	BLACK	3036859
18	FAN SPEED SWITCH (2)	SOLDER	FAN MOTOR (SEE DIAGRAM)	6.3mm FASTON & BOOT	YELLOW	3036860
19	MAINS CONNECTION BLOCK (N)	6.3mm FASTON & BOOT	COMPRESSION RELAY (N)	6.3mm PIGGYBACK FASTON	BLUE	3036843
20	MAINS CONNECTION BLOCK (L)	6.3mm FASTON & BOOT	BUCKET 3/4 FULL M/SWITCH (1)	6.3mm FASTON	BROWN	3036844
21	MAINS CONNECTION BLOCK (L)	6.3mm FASTON & BOOT	BUCKET FULL M/SWITCH (1)	6.3mm FASTON & BOOT	BROWN	3036845
22	MAINS CONNECTION BLOCK (E)	6.3mm LOCKING FASTON	COMPRESSION RELAY (E)	M4 FORK	GRN/YELL	3036846

Wiring information (after serial 57009802) for models:- 11448 (480), 11488 (880), 11498 (980)

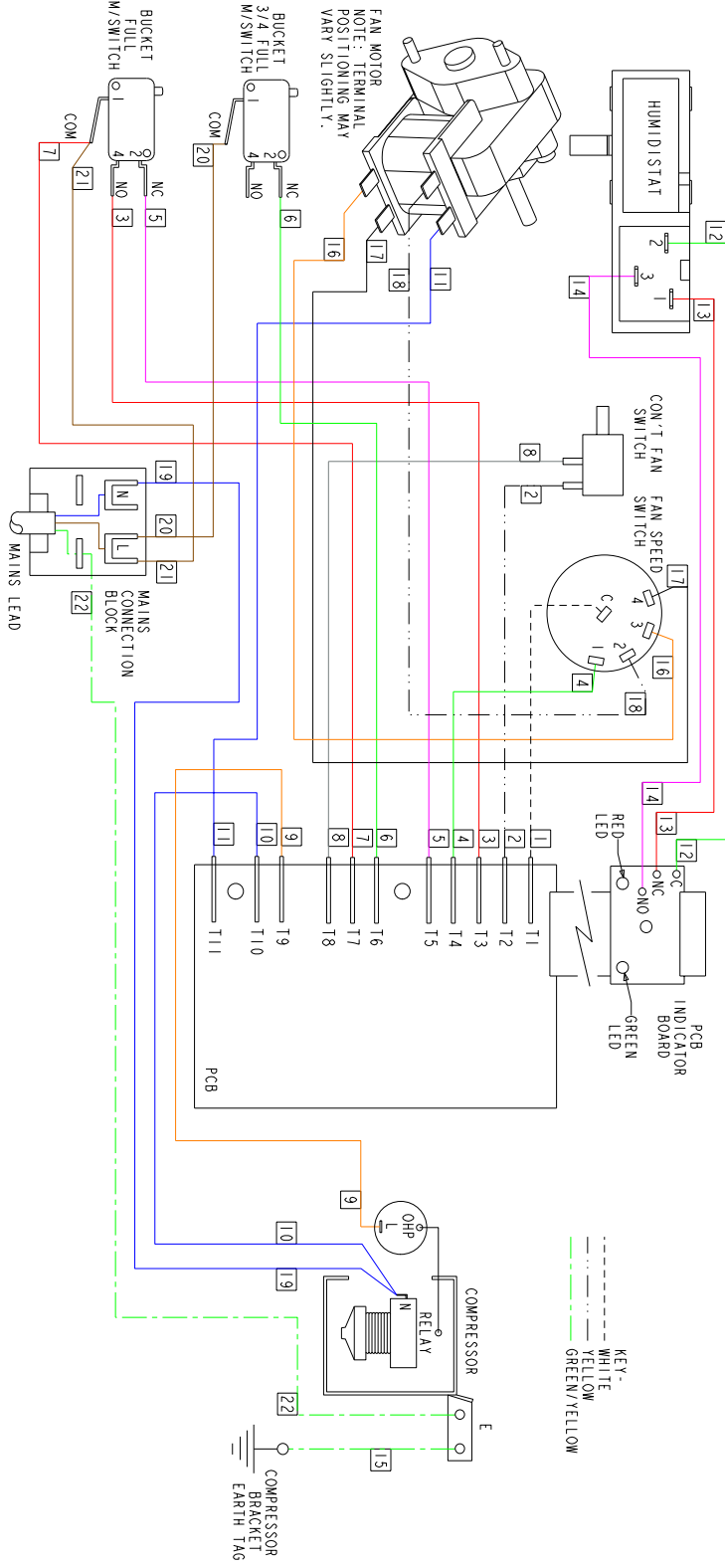

WIRE No.	FROM	TERMINATION	TO	TERMINATION	COLOR	PART No.
1	PCB T1	2.8mm FASTON & BOOT	FAN SPEED SWITCH (C)	SOLDER	WHITE	3038862
2	PCB T2	2.8mm FASTON & BOOT	CONTINUOUS FAN SWITCH	SOLDER	YELLOW	3038863
3	PCB T3	2.8mm FASTON & BOOT	BUCKET FULL M/SWITCH (4)	6.3mm FASTON & BOOT	RED	3038851
4	PCB T4	2.8mm FASTON & BOOT	FAN SPEED SWITCH (1)	SOLDER	GREEN	3038861
5	PCB T5	2.8mm FASTON & BOOT	BUCKET FULL M/SWITCH (2)	6.3mm FASTON & BOOT	VIOLET	3038852
6	PCB T6	2.8mm FASTON & BOOT	BUCKET 3/4 FULL M/SWITCH (2)	6.3mm FASTON & BOOT	GREEN	3038853
7	PCB T7	2.8mm FASTON & BOOT	BUCKET FULL M/SWITCH (1)	6.3mm PIGGYBACK FASTON	RED	3038850
8	PCB T8	2.8mm FASTON & BOOT	CONTINUOUS FAN SWITCH	SOLDER	GREY	3038864
9	PCB T9	2.8mm FASTON & BOOT	COMPRESSOR OHP (L)	6.3mm FASTON	ORANGE	3038848
10	PCB T10	2.8mm FASTON & BOOT	COMPRESSOR RELAY (N)	6.3mm FASTON	BLUE	3038849
11	PCB T11	2.8mm FASTON & BOOT	FAN MOTOR (SEE DIAGRAM)	6.3mm FASTON & BOOT	BLUE	3038857
12	PCB INDICATOR BOARD (C)	SOLDER	HUMIDISTAT (2)	6.3mm 90° FLAG & BOOT	GREEN	3038855
13	PCB INDICATOR BOARD (NC)	SOLDER	HUMIDISTAT (1)	6.3mm 90° FLAG & BOOT	RED	3038856
14	PCB INDICATOR BOARD (NO)	SOLDER	HUMIDISTAT (3)	6.3mm 90° FLAG & BOOT	VIOLET	3038854
15	COMPRESSOR (E)	M4 FORK	COMPRESSOR / BRACKET EARTH TAG	M4 RING	GRN/YELL	3038847
16	FAN SPEED SWITCH (3)	SOLDER	FAN MOTOR (SEE DIAGRAM)	6.3mm FASTON & BOOT	ORANGE	3038858
17	FAN SPEED SWITCH (4)	SOLDER	FAN MOTOR (SEE DIAGRAM)	6.3mm FASTON & BOOT	BLACK	3038859
18	FAN SPEED SWITCH (2)	SOLDER	FAN MOTOR (SEE DIAGRAM)	6.3mm FASTON & BOOT	YELLOW	3038860
19	MAINS CONNECTION BLOCK (N)	6.3mm FASTON & BOOT	COMPRESSOR RELAY (N)	6.3mm PIGGYBACK FASTON	BLUE	3038843
20	MAINS CONNECTION BLOCK (L)	6.3mm FASTON & BOOT	BUCKET 3/4 FULL M/SWITCH (1)	6.3mm FASTON	BROWN	3038844
21	MAINS CONNECTION BLOCK (1)	6.3mm FASTON & BOOT	BUCKET FULL M/SWITCH (1)	6.3mm FASTON & BOOT	BROWN	3038845
22	MAINS CONNECTION BLOCK (E)	6.3mm LOCKING FASTON	COMPRESSOR (E)	M4 FORK	GRN/YELL	3038846

### 10.0 COMPONENT IDENTIFICATION

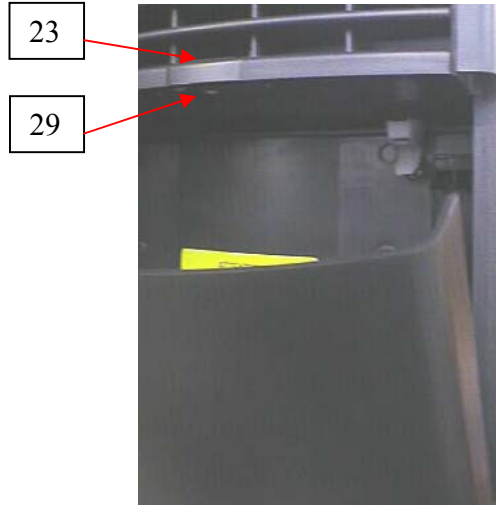
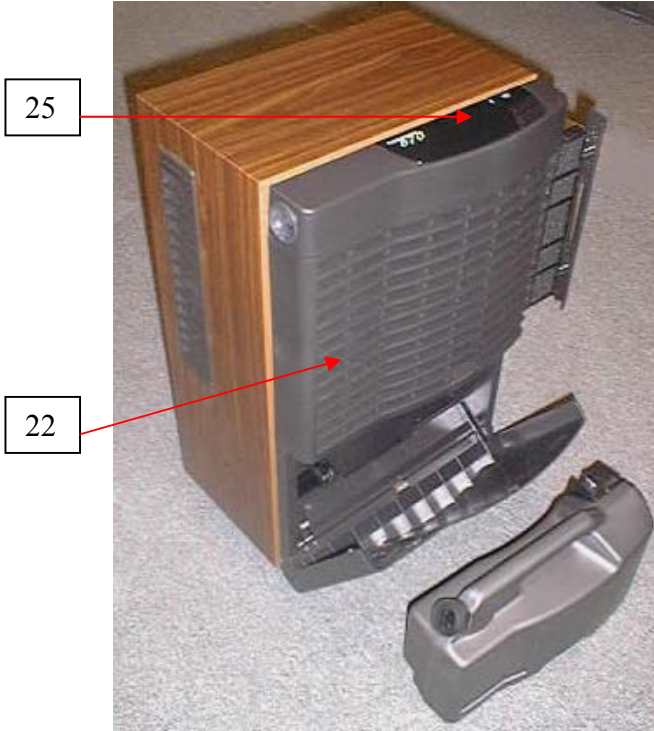

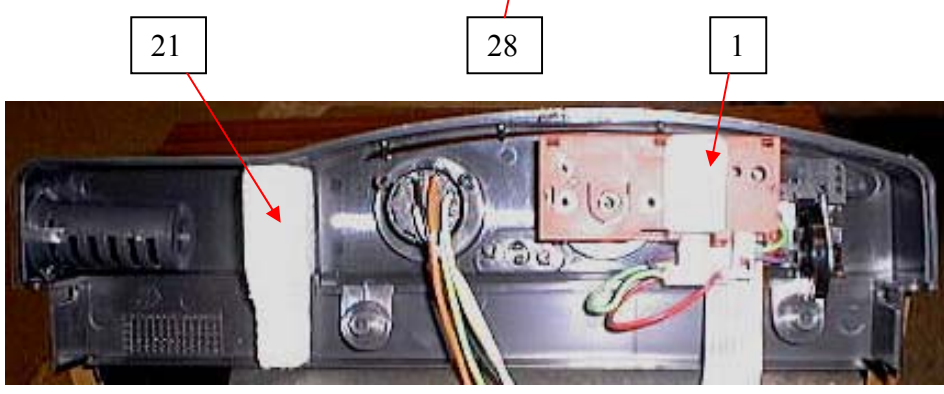
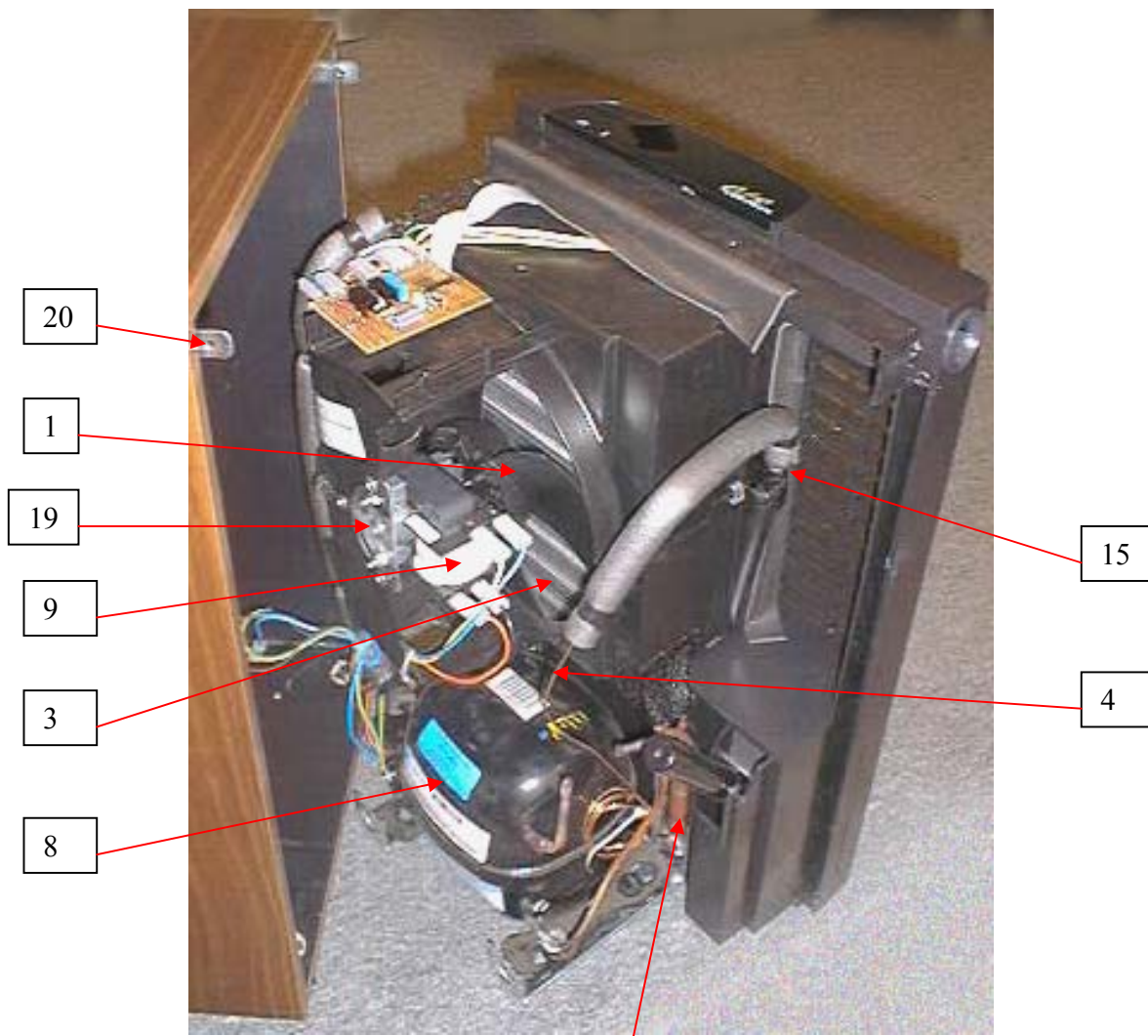

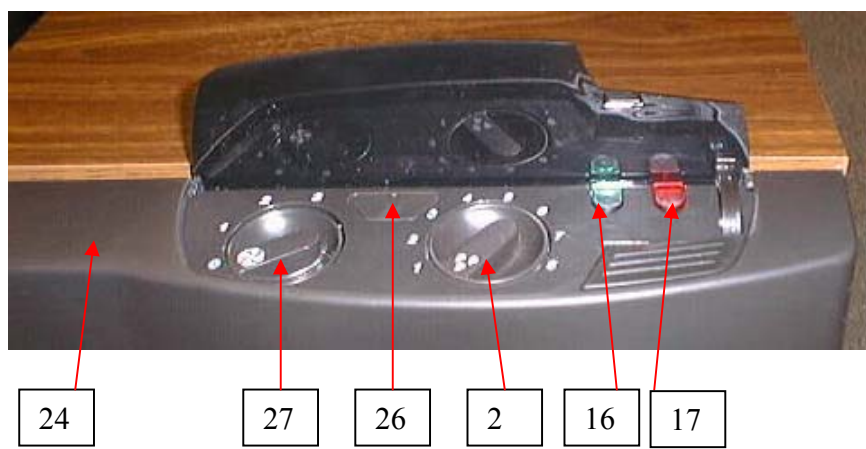
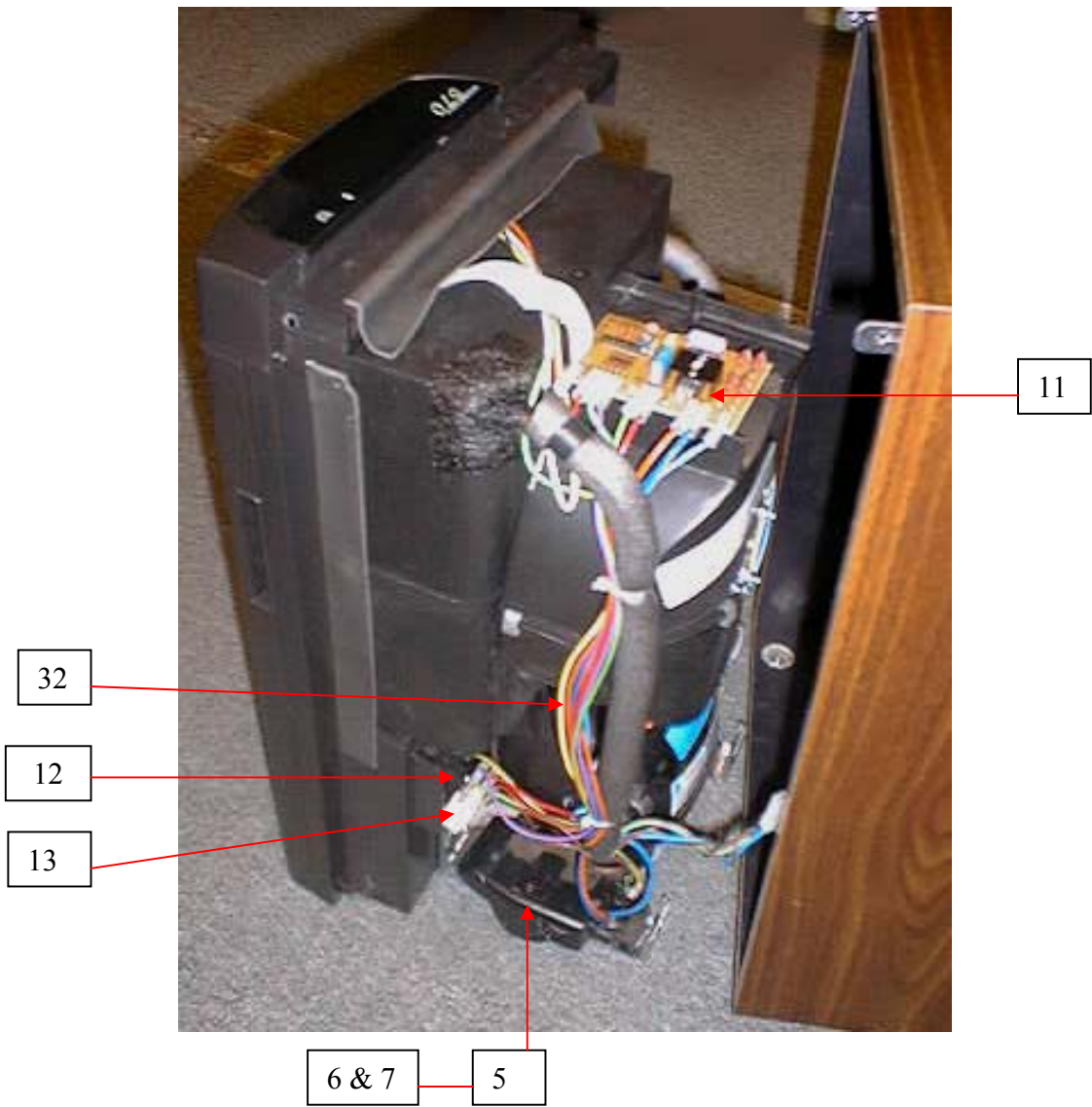

## SPARES LIST

NO	Part Number	Description
1	3035143	HUMIDISTAT
2	2140231	HUMIDISTAT KNOB
3	2140800	CONDENSER COIL
4	3014275	CAPILLIARY
5	3021518	COMPRESSOR BOX COVER
6	3021543	OHP
7	3021544	RELAY
8	3022147	COMPRESSOR
9	3035773	MOTOR
10	3040129	AXIAL FAN
11	1618022	PCB (870 MODEL ONLY)
11	1618021	PCB (880 MODEL ONLY)
12	2140005	LEVER, MICROSWITCH FLOAT
13	3033032	MICROSWITCH
14	2141094	MAINS POWER CABLE 2m
15	2140601	EVAPORATOR 600
16	2140019	GREEN INDICATOR LENS
17	2140020	RED INDICATOR LENS
18	2140025	BLACK CABLE CLIP
19	2017731	FAN MOTOR BRACKET
20	2140017	CABINET / GRILLE BRACKET
21	2140033	POLYSTYRENE BAFFLE
22	2140330	FRONT GRILLE
23	2140360	BUCKET DOOR BUTTON
24	2140300	CONTROLS HOUSING
25	1140821	TINTED CONTROL COVER FLAP
26	2140261	BLANK / DUMMY BUTTON
27	1140827	FAN SPEED KNOB
28	3020937	FILTER DRYER
29	2140028	BUCKET DOOR CATCH

## 12.0 FAULT DIAGNOSIS

**SAFETY NOTE: Do not remove the cabinet unless the unit is removed from the power supply.**

SYMPTOM	POSSIBLE CAUSES	REMARKS
Unit Dead, Indicators OFF	Faulty/loose mains lead Loose wiring Faulty PCB	
Unit Dead, Indicators ON	Loose wiring Faulty PCB	
Fan Running & Compressor Dead	Loose wiring Faulty PCB Compressor Fault	
Faulty Fan Speeds	Faulty Switch Faulty PCB Ribbon Cables Loose	
Undercharge/Blockages	Leakage in fridge circuit	
Defrost	Faulty PCB Polystyrene baffle missing Sealing around controls missing	
Poor Performance	Positioning of unit Low/High refrigerant charge Dirty/blocked air filter	

Ebac Industrial Products, Inc.  
700 Thimble Shoals Blvd, Suite 109  
Newport News, VA. 23606-2575  
Tel: (757) 873 6800 Fax: (757) 873 3632  
Website [www.ebacusa.com](http://www.ebacusa.com)

